

Supported by

Intelligent Energy  **Europe**

Energy saving concepts for the European ceramic industry
CERAMIN



Contract number
EIE/06/222/SI2.444565

Tutorial about Energy saving
(Without electric energy)

Responsible for that tutorial: *Rüdiger Köhler*, KI Keramik-Institut GmbH, D 01662 Meißen

The sole responsibility for the content of this publication lies with the authors. It does not necessarily reflect the opinion of the European Communities. The European Commission is not responsible for any use that may be made of the information contained therein.



Table of Contents

0	Introduction.....	3
1	General Remarks	7
2	Masonry bricks	8
3	Pavement and facing bricks	15
4	Roof tiles and split tiles.....	21
5	Tableware.....	28
6	Sanitary ware	35
7	Tiles.....	40
8	References	46

0 Introduction

The CERAMIN project was created to encourage the European Ceramics industry to decrease their specific energy consumption (SEC) by means of a competition and by a tutorial about energy saving for the ones who haven't won.

Ceramic companies from all EU-countries and all ceramic branches were invited to take part in a competition to achieve the lowest SEC and the greatest relative SEC reduction. The plan was to reach in the first phase, 60 companies from at least 6 European countries. The expert partners of the CERAMIN-project are introduced at <http://www.ie-leipzig.com/Ceramin/partners.htm>

Table 1 shows the number of participating companies per branch and country after the first period, it shows all branches that were covered and it shows the partner countries. The branches with the most participating companies are the pavements and wall bricks branch as well as the refractories and tableware branch. Unfortunately there was no reported data from Italy and only a few from Spain and France.

	UK	E	F	I	D	PL	Sum of branches
Masonry bricks					1	2	3
Pavement and wall bricks	9				13	2	24
Roof tiles						1	1
Refractories	2	3	1			1	7
Wall and floor tiles	1		2			1	4
Sanitary ware			1		1	1	3
Table ware	3		1			2	6
Technical ceramics							0
Sum of Countries	15	3	5	0	15	10	48

Table 1: Number of companies per branch and country that take part in the CERAMIN project until 31.12.2008



Table 2 shows the results of the competition. The rules for calculation of energy mitigation are attached (attachment 1). According to the rules, at least two years of production of one company had to be covered. From these two years, only one result of mitigation per company is calculated. For this reason both last columns of table 2 are empty for the base year. The participating companies are sorted by branch and the level of energy mitigation. Only the first 5 (if available) of energy mitigation and the best of absolute SEC per branch are listed. The data was not verified initially with the exception of the heavy ceramics branches where verification according to EUTS was available for most of the companies.

Coincidentally when the collecting of data in table 2 was completed, the economic problems of the year 2009 arose. As a result of these problems, the willingness of companies to participate decreased in an unpredictable manner. For this reason only very few companies were ready to give data about their own success of energy saving to the respective project expert partners.^{50, 51}

The remarks or recommendations of the following paper are based on general experiences and on a lot of references marked in the text and the references list at the end of this tutorial. Both were given or collected by the expert partners:

- CERAM Research Ltd. (UK) – www.ceram.com
- Instytut Szkła, Ceramiki, Materialow Ogniotrwalych i Budowlanych (PL) – www.isic.waw.pl
- Societe Francaise de Ceramique (F) – www.ceramique.fr
- KI Keramik-Institut GmbH (D) – www.ceramics-institute.com

	Enter- prise No.	No. of Plant	Branch	Sum of energy consumption [GJ]	SEC [GJ/t]	Place- ment absolute	Energy miti- gation	Place- ment mitigation
D	1	1	Masonry...	15.308	2,69	4	0,92	1
PL	PL-3	PL-3	Masonry...	181.290	1,34	1	0,38	2



PL	PL-5	PL-5-2	Masonry...	145.052	2,17	2	0,29	3
PL	PL-5	PL-5-2	Masonry...	138.090	2,61	3		
PL	PL-3	PL-3	Masonry...	287.464	2,76	5		
D	1	1	Masonry...	20.885	3,60	6		
UK	5	1	Pavement...	56.609	10,63	42	3,81	1
UK	3	1	Pavement...	21.388	4,24	32	1,63	2
UK	8	1	Pavement...	9.768	3,16	25	1,10	3
UK	6	1	Pavement...	19.413	5,83	38	0,97	4
D	6	1	Pavement...	90.670	4,72	35	0,40	5
UK	1	1	Pavement...	4.135	1,43	2	-0,05	16
UK	1	1	Pavement...	4.024	1,37	1		
UK	8	1	Pavement...	13.168	4,26	33		
D	6	1	Pavement...	99.921	5,12	37		
UK	3	1	Pavement...	35.812	5,88	39		
UK	6	1	Pavement...	21.743	6,80	40		
UK	5	1	Pavement...	62.746	14,45	46		
PL	PL-5	PL-5-1	roof...	78.481	4,27		12,08	
PL	PL-5	PL-5-1	roof...	34.822	22,38			
UK	9	1	refractories	90.397	16,31	11	6,27	1
E	2	2	refractories	44.031	8,16	7	1,72	2
PL	PL-4	PL-4	refractories	304.986	4,91	3	1,13	3
F	D	1	refractories	50.026	10,88	8	0,51	4
E	2	1	refractories	57.675	3,77	1	0,24	5
E	2	1	refractories	53.184	4,66	2		
PL	PL-4	PL-4	refractories	347.730	6,04	4		
F	D	1	refractories	45.543	11,39	9		
E	2	2	refractories	51.487	13,32	10		
UK	9	1	refractories	145.421	25,72	12		
UK	13	1	tiles	475.346	8,80	7	0,67	1
PL	PL-1	PL-1	tiles	505.728	5,13	3	0,28	2
F	C	1	tiles	212.677	8,33	5	0,13	3
F	B	1	tiles	300.240	5,12	2	-0,12	4
F	B	1	tiles	349.200	5,00	1		
PL	PL-1	PL-1	tiles	356.082	5,55	4		
F	C	1	tiles	196.815	8,73	6		
UK	13	1	tiles	491.282	9,46	8		



F	A	1	sanitary...	176.090	20,79	5	3,02	1
PL	PL-7	PL-7	sanitary...	118.560	10,68	1	1,03	2
D	13	1	sanitary...	81.472	10,76	2	0,65	3
D	13	1	sanitary...	82.198	12,07	3		
PL	PL-7	PL-7	sanitary...	138.484	14,69	4		
F	A	1	sanitary...	178.351	25,33	6		
UK	11	1	table...	131.907	56,35	10	13,18	1
PL	PL-8	PL-8	table...	259.203	44,57	5	4,96	2
F	E	1	table...	125.536	52,39	6	3,90	3
PL	PL-2	PL-2	table...	454.358	31,21	1	1,96	4
UK	12	1	table...	241.809	33,13	2	1,01	5
PL	PL-2	PL-2	table...	299.109	36,10	4		
UK	12	1	table...	277.784	34,65	3		
PL	PL-8	PL-8	table...	287.050	54,50	8		
F	E	1	table...	122.729	56,30	9		
UK	11	1	table...	169.593	76,12	12		

Table 2: Top 5 of participating companies concerning energy mitigation per branch (if 5 participants available) and best participant of specific energy consumption (SEC) per branch.



1 General Remarks

1.1 About the tutorial

The tutorial is structured by ceramic branches. A lot of recommendations are applicable for more than one branch or are at least similar for different branches; hence these recommendations are repeated for each branch where applicable.

Please bear in mind: Only a few recommendations will fit your respective production or your needs about costs and benefits.

1.2 Recommendations with common validity

- Where a plant in whole, or part is used at full scale, will have a lower specific energy consumption (SEC) compared to working below its designed capacity.
- Although electric power consumption of ceramic production is not taken into consideration, the cogeneration of heat and power could be a good strategic decision to consider in saving energy and costs.

2 Masonry bricks

2.1 Body and raw materials

- Additives for improving the insulation should be also energy sources. The combustion temperature of these additives has to overlap a broad temperature range. Waste graphite⁴⁷, Petroleum coke¹⁷ or coal-clays¹⁹ can help you to get sintering energy up to 800 °C.
- Sintering additives like ashes, waste glasses, glass and mineral wools or low sintering clays can help you to reduce the sintering temperature or to produce (dry and fire) lighter products with same mechanical properties.^{47, 29, 35, 65}
- Shaping needs plasticity, especially for modern lattice bricks. It is necessary that the right amount of water is used to get the correct plasticity. Saving water by using better clays that are easy to form or adding special additives that help to get the correct plasticity is a way to save drying energy.^{47,48,21,37}

2.2 Shaping

- It's possible to save energy by stiff pressing. However, not all body formulations are suitable, as sometimes the energy saving is consumed at the extruding press as electric energy and finishing.^{48, 1}
- Try to use the shaping (extruding) temperature while entering the dryer.^{36, 5, 6, 26}

2.3 Drying

In the ceramic industry, drying generally means the evaporation or volatilisation of physically bound water. It is well known that water is characterised by a high specific thermal capacity (4.2 kJ/kg K) and a very high evaporation heat (2.500 kJ/kg). These material properties inevitably cause a high-energy consumption. The only objective can be to approach the theoretical (minimum) consumption as close as possible. Figure 1 shows: At the moment up to 50 % of thermal energy in ceramic production is used for drying⁴⁹ however in the UK where a lot of stiff pressed bodies are used still 30% of thermal energy is used for drying.⁹

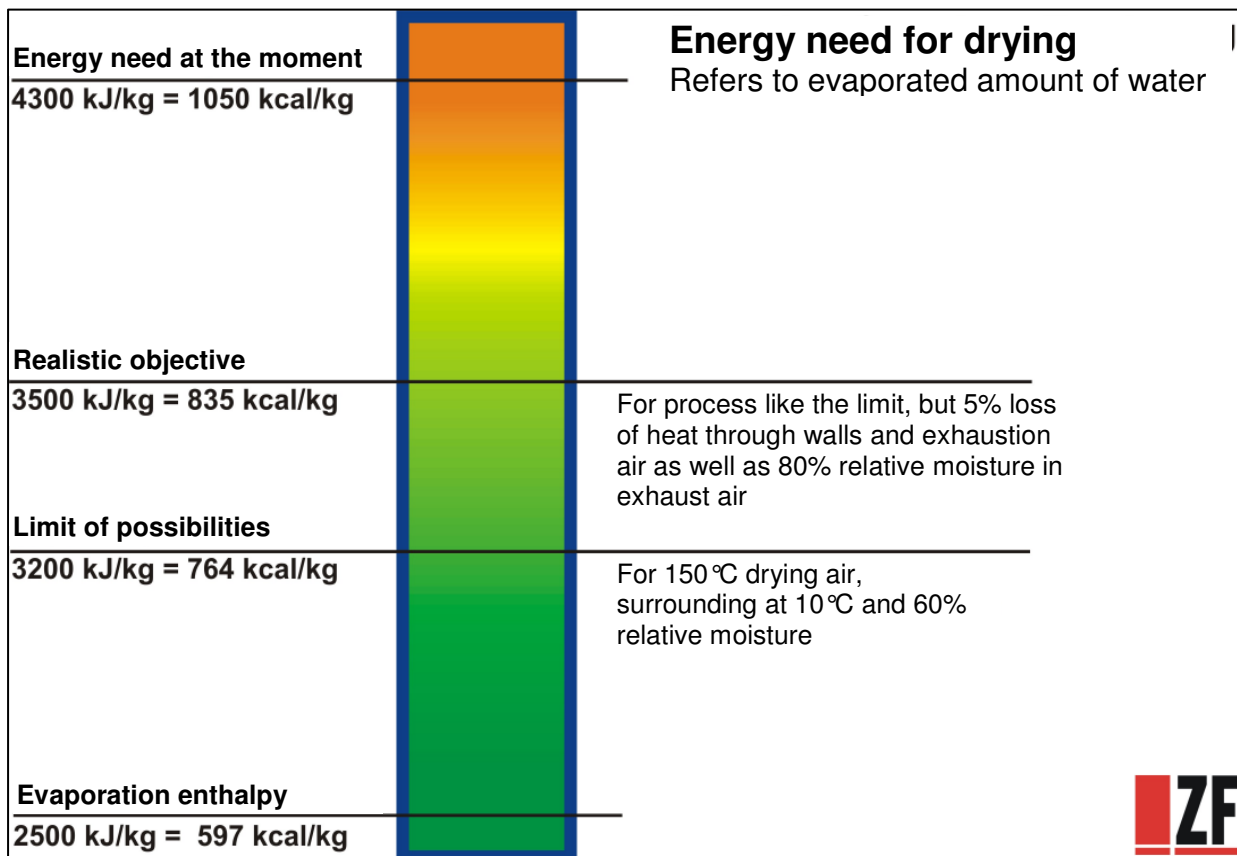

Figure 1: State of the art of drying

- A common way to reduce the drying energy consumption in older companies is to couple the dryer and kiln.⁷

- Today the coupling of dryer and kiln is state of the art, however it is also important to modify working practices i.e. weekend breaks for shaping and drying need to be carefully controlled.⁴³
- Another method of modernising is to control the ventilation/burner system and the drying atmosphere.⁶
- The use of small amounts of high temperature air, decreases air loss due to exhaust gases.^{36, 45, 49}
- The air should flow through lattice bricks.⁴⁷
- Figure 2 shows that lowest energy costs (heat and electric) which can be reached at an optimum of heating energy and movement of drying air.

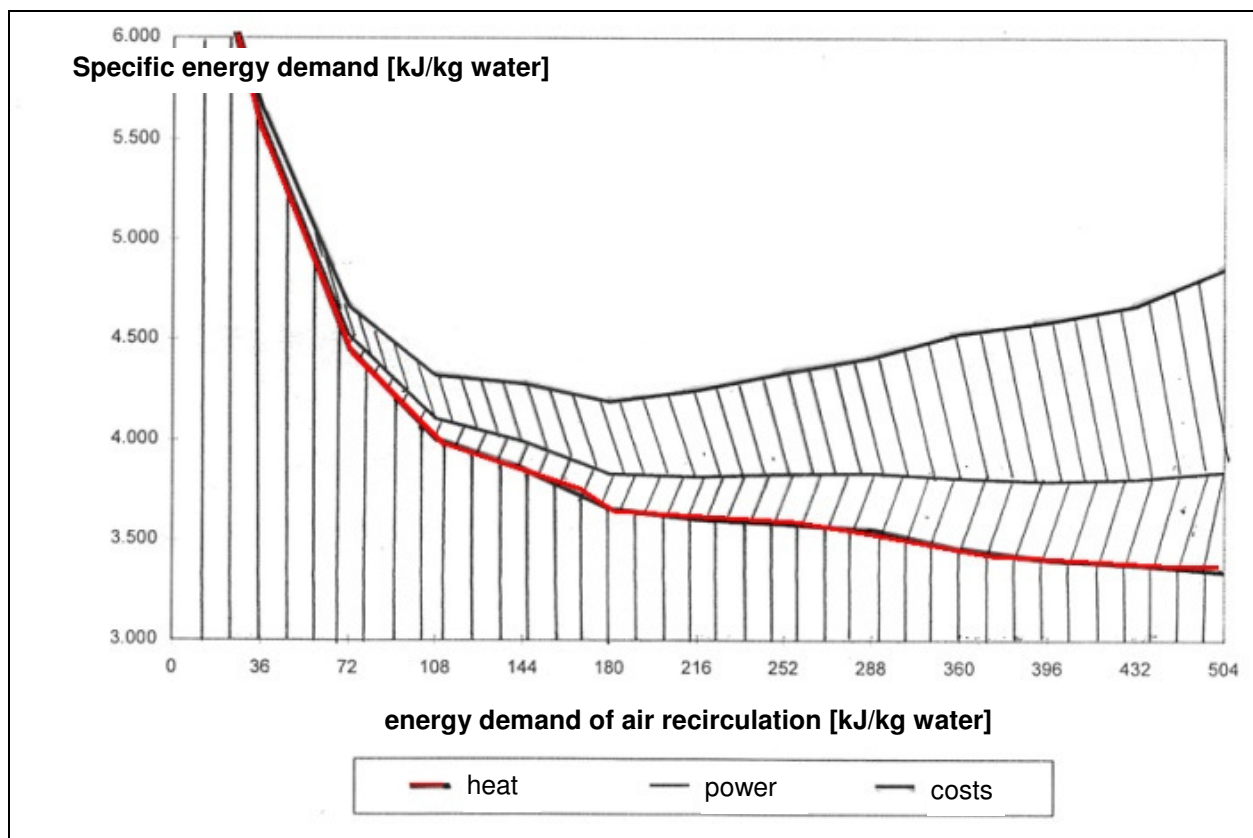

Figure 2: Energy demand of heat vs. energy demand of air recirculation in dryers

- The setters and the setting density should ensure that most of the surfaces are easy reached by the drying air.⁵
- Shorter drying times save energy.^{5, 6, 41, 44}

- To achieve the required humidity for drying avoid adding moisture and if required increase the setting density.⁹
- Redirecting airflows can improve consistency and reduce drying time; intermittent airflow patterns can reduce drying time and improve yield.⁹
- Software to simulate the drying process. Links to control data via specialized companies are a good way to optimise drying.³⁶
- In the case of a coupled system between dryer and kiln, the kilns energy supply and not the dryers demand determines the energy level that the dryer gets, otherwise poor energy use in the dryer causes a higher energy consumption for firing.^{36, 42}
- The system that connects the hot air from the kiln with the dryer should be well insulated.⁴⁷
- Most modern drying equipment and technology can save up to 90% of drying time compared to conventional drying.⁴⁹
- Alternative drying systems are available using a steam atmosphere, this is called 'airless drying' and is claimed to have reduced drying times up to 80%.⁶³
- Alternative I/R burner systems are available using a mesh, these can be powered by a number of different gases are easy to control and are very energy efficient. These can be incorporated into existing dryer cabinets.⁶⁴

2.4 Firing

The specific energy consumption for sintering ceramic products depends on the required firing temperature. The temperature is determined by the composition of the body, the processes of material formation and the intended properties. Figure 3 shows an exponential increase of the specific demand for energy with the temperature.

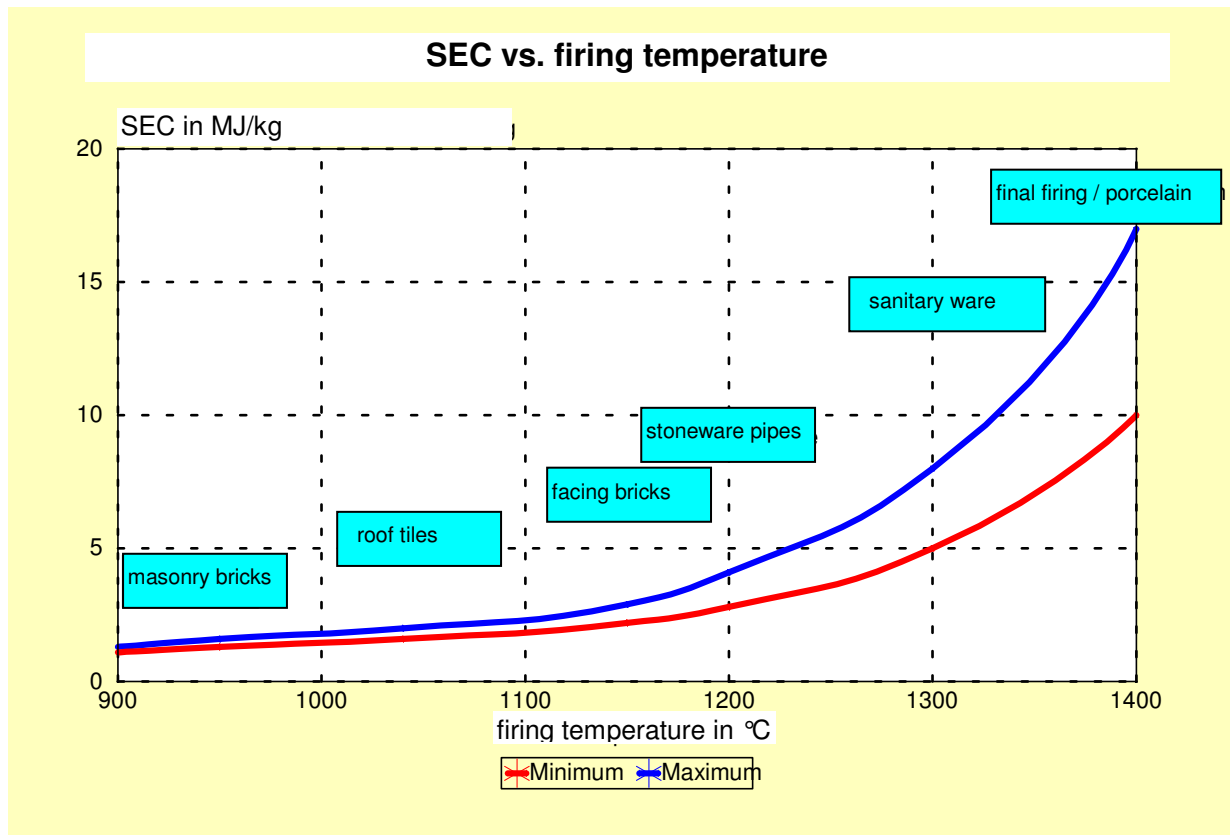

Figure 3: Energy consumption of different ceramic products with its different firing temperatures.⁴⁸

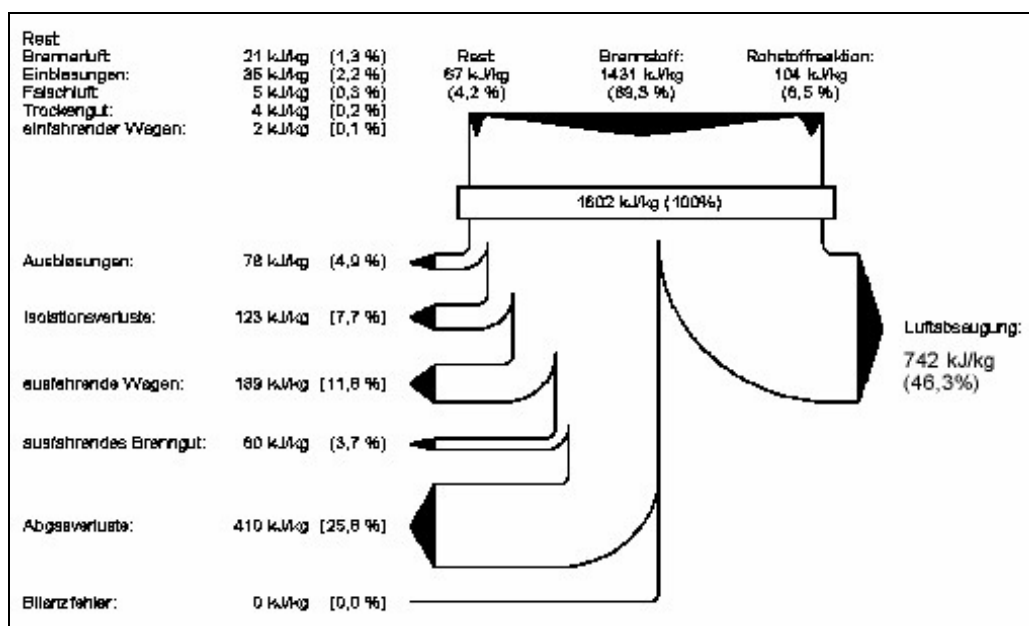

Figure 4: Balance of a tunnel kiln for masonry bricks (Sankey Figure)⁴⁷

Figure 4 shows the energy balance of a tunnel kiln for masonry bricks. The values of greatest energy loss are the different exhaust air streams partly used for drying.

2.4.1 Kiln and kiln car design

There are two general ways of energy loss influenced by the design of the kiln and the kiln cars:

1. Leakages from surrounding air into the kiln

”However one of the best possibilities to save energy is still to eliminate leakages” Don Denison, Denison Inc.²¹

2. Weight of kiln materials and kiln car materials that have to be heated

- “Wheel flanges of kiln car wheels should in principle should be located on the outside”.²
- “The kiln car decks should consist of high quality and lightweight insulating materials with a minimum content of heavy chamotte. It is recommended that the layers from the bottom deck to the top deck should be adapted to cope for the different respective temperature stresses”.^{2, 3, 20}
- A picture for calculating the optimum car deck thickness can be seen in ².
- Sand seals should be designed to avoid leakages over a long time, suggestions are made in ^{2, 33}.
- Try to avoid self-supporting kiln sidewalls. Such walls tend to bend towards the firing channel because of the temperature differences over the cross section. It is important to consider the design very carefully and have a wall sustained by the kiln roof. ²
- Special designed kiln roofs avoid leakages due to heat expansion and make roof cooling redundant.²

2.4.2 Fuel and firing technology

- In the main firing zone an excess pressure of 10-15 Pa is recommended.⁷⁴
- For some brick producers it is still a possibility to make energy savings by changing from solid fuel like coal to LPG or oil which will increase the energy efficiency.⁵¹
- Use of renewable energies, i.e. biogases produced by companies in their own reactors can save costs and CO₂ emissions¹¹; however biogases can't cover the whole energy need of a brick maker.⁴⁷
- Increasing control of firing with new burner systems and multi zone control.^{33,51,34}
- Impulse burners are more efficient than conventional ones.⁷⁴
- High velocity burners (velocity of heated gases > 100 m/s) are recommended for the preheating zone until 700 °C. At this lower temperature heating by convection mostly takes place. Kilns can be modernised with these modern burners, to save energy.⁷⁴
- Techniques already described for drying are also important for firing: allow the hot gases best heat transition to your working load.^{33,34}
- The combustion air should be preheated; at higher firing temperatures preheating saves energy. The preheating should be done by using kiln exhaust air.⁴⁰
- Use preheated working loads from the dryer, e.g. setting pallets for drying and firing or by direct setting on kiln cars for drying.^{1,23}
- The final development that some producers in the brick industry have used is emissivity coatings in certain sections of the kiln to reflect the heat to the required area thus reducing the temperature lag between 'part' and surrounding air. This in theory has reduced gas costs by up to 10%.⁵¹
- Reduce waste air losses by re-circulating them for heating over the whole length of kiln.³³
- The hot gases should pass through the holes of bricks to increase the area between load and hot gases called 'Perfusion firing'.⁴⁷
- Use heat recovery from waste gases and flue gas from post combustion.^{18,47}

3 Pavement and facing bricks

3.1 Body, raw materials

- Sintering additives like ashes, waste glasses, glass and mineral wools or low sintering clays can help you to reduce sintering temperature or to produce (dry and fire) lighter products with same mechanical properties.^{47,29,35,65}
- Shaping needs plasticity: It is necessary that the right amount of water is used to get the correct plasticity. Saving water by using better clays that are easy to form or adding special additives that help to get the correct plasticity is a way to save drying energy.^{47,48,21,37}
- The use of special additives for surface effects can look like flashed bricks. This can give gas savings while flashing.²¹

3.2 Shaping

- It is possible to save energy by stiff pressing. However this is not suitable for all bodies, sometimes the saved drying energy is consumed at the extruding press as electric energy and finishing.^{48,1}
- Re-use the temperature used for shaping while entering the dryer.^{36,1,5,6,26}
- Sophisticated designs can save weight of e.g. pavement bricks, by saving on the mass off the surface that is embedded into the soil. Design saving are also possible for facing bricks. An easy lattice allows energy saving by perfusion while drying or firing.
- Dry shaping or shaping in the dryer saves energy, but it uses more energy for shaping and can influence the quality of product, however there is an optimum.²¹

3.3 Drying

In the ceramic industry drying generally means the evaporation or volatilisation of physically bound water. It is well known that water is characterised by a high specific thermal capacity (4.2 kJ/kg K) and a very high evaporation heat (2.500 kJ/kg). These material properties inevitably cause a high energy consumption. The only objective can be to approach the theoretical (minimum) consumption as close as possible. Figure 1 shows: At the moment up to 50 % of thermal energy in ceramic production is used for drying.⁴⁹ In the UK with its majority of stiff pressed bodies however 30% thermal energy is still used.⁹

- A common way to reduce the drying energy consumption in older companies is to couple the dryer and kiln.⁷
- Today the coupling of dryer and kiln is state of the art, however it is also important to modify working practices i.e. weekend breaks for shaping and drying need to be carefully controlled.⁴³
- Another method of modernising is to control the ventilation/burner system and the drying atmosphere.⁶
- The use of small amounts of high temperature air, decreases air loss due to exhaust gases.^{36, 45, 49}
- The air should flow through lattice bricks.⁴⁷
- Figure 2 shows that lowest energy costs (heat and electric) which can be reached at an optimum of heating energy and movement of drying air.
- The setters and the setting density should ensure that most of the surfaces are easy reached by the drying air.⁵
- Shorter drying times save energy.^{5, 6, 41, 44}
- To achieve the required humidity for drying avoid adding moisture and if required increase the setting density.⁹
- Redirecting airflows can improve consistency and reduce drying time; intermittent airflow patterns can reduce drying time and improve yield.⁹
- Software to simulate the drying process. Links to control data via specialized companies are a good way to optimise drying.³⁶

- In the case of a coupled system between dryer and kiln, the kilns energy supply and not the dryers demand determines the energy level that the dryer gets, otherwise poor energy use in the dryer causes a higher energy consumption for firing.^{36, 42}
- The system that connects the hot air from the kiln with the dryer should be well insulated.⁴⁷
- Most modern drying equipment and technology can save up to 90% of drying time compared to conventional drying.⁴⁹
- Alternative drying systems are available using a steam atmosphere, this is called 'airless drying' and is claimed to have reduced drying times up to 80%.⁶³
- Alternative I/R burner systems are available using a mesh, these can be powered by a number of different gases are easy to control and are very energy efficient. These can be incorporated into existing dryer cabinets.⁶⁴
- Modern setter systems as shown in Figure 5 can save energy.⁴⁹



Figure 5: MobilSystem by Rotho- channel for facing or pavement bricks.⁴⁹

3.4 Firing

The specific energy consumption for sintering ceramic products depends on the required firing temperature. The temperature is determined by the composition of the body, the processes of material formation and the intended properties. Figure 3 shows an exponential increase of the specific demand for energy with the temperature.

Figure 4 shows the energy balance of a tunnel kiln for masonry bricks. The values of greatest loss are different exhaustion air streams partly used for drying.

3.4.1 Kiln and kiln car design

There are two general ways of energy loss influenced by the design of the kiln and the kiln cars:

1. Leakages from surrounding air into the kiln

”However one of the best possibilities to save energy is still to eliminate leakages” Don Denison, Denison Inc.²¹

2. Weight of kiln materials and kiln car materials that have to be heated

- “Wheel flanges of kiln car wheels should be in principle located on the outside”.²
- “The kiln car decks should consist of high quality and lightweight insulating materials with a minimum content of heavy chamotte. It is recommended that the layers from the bottom deck to the top deck should be adapted to cope for the different respective temperature stresses”.^{2, 3, 20}
- A picture for calculating the optimum car deck thickness can be seen in ².
- Sand seals should be designed to avoid leakages over a long time, suggestions are made in ^{2, 33}.

- Try to avoid self-supporting kiln sidewalls. Such walls tend to bend towards the firing channel because of the temperature differences over the cross section. It is important to consider the design very carefully and have a wall sustained by the kiln roof. ²
- Special designed kiln roofs avoid leakages due to heat expansion and make roof cooling redundant. ²

3.4.2 Fuel and firing technology

- In the main firing zone an excess pressure of 10-15 Pa is recommended. ⁷⁴
- For some brick producers it is still a possibility to make energy savings by changing from solid fuel like coal to LPG or oil which will increase the energy efficiency. ⁵¹
- Use of renewable energies, i.e. bio-gases produced by companies in their own reactors can save costs and CO₂ emissions. ¹¹ However, bio-gases can't cover the whole energy need of a brick maker. ⁴⁷
- Increasing control of firing with new burner systems and multi zone control. ^{33,51,34}
- Impulse burners are more efficient than conventional ones. ⁷⁴
- High velocity burners (velocity of heated gases > 100 m/s) are recommended for the preheating zone until 700 °C. At this lower temperature heating by convection mostly takes place. Kilns can be modernised with this modern kind of burner, to save energy. ⁷⁴
- Techniques already described for drying are also important for firing.
- Allow the hot gases the best transfer to your working load. ^{33,34}
- The combustion air should be preheated; at higher firing temperatures preheating saves energy. The preheating should be done by using kiln exhaust air. ⁴⁰
- Use preheated working loads from the dryer, e.g. setting pallets for drying and firing or by direct setting on kiln cars for drying. ^{1,23}



- The final development that some in the brick industry have used is emissivity coatings in certain sections of the kiln to reflect the heat to the required area thus reducing the temperature lag between 'part' and surrounding air. This in theory has reduced gas costs by up to 10%.⁵¹
- Reduce waste air losses by re-circulating them for heating over the whole length of kiln.³³
- Perfusion firing.⁴⁷
- Use heat recovery from waste gases and flue gas from post combustion.^{18,47}
- One tunnel kiln shall work with one product and shall be optimised for that product. With different products in kiln no real optimisation can take place. Think about small intermittent kilns for special products or about cooperation with different plants or about reducing the number of different product types.⁹

4 Roof tiles and split tiles

4.1 Body and raw materials

- Sintering additives like ashes, waste glasses, glass and mineral wools or low sintering clays can help you to reduce sintering temperature or to produce (dry and fire) lighter products with same mechanical properties. ^{47,29,35,65}
- Shaping needs plasticity. It is necessary that the right amount of water is used to get the correct plasticity. Saving water by using better clays that are easy to form or adding special additives that help to get the correct plasticity is a way to save drying energy. ^{47,48,21,37}

4.2 Shaping

- It's possible to save energy by stiff pressing. Not all bodies are suitable for this, sometimes the saved drying energy is consumed at the extruding press as electric energy and finishing - only split tiles. ^{48,1}
- Try to use the shaping temperature while entering the dryer. ^{36,1,5,6}
- Sophisticated designs can save weight that allows energy saving while drying or firing.
- Dry or dryer shaping saves drying energy, but uses more energy for shaping and can influence the quality of product. However there is an optimum. ²¹

4.3 Drying

In the ceramic industry drying generally means the evaporation or volatilisation of physically bound water. It is well known that water is characterised by a high specific thermal capacity (4.2 kJ/kg K) and a very high evaporation heat (2.500 kJ/kg). These material properties inevitably cause a high-energy consumption. The only objective can be to approach the theoretical (minimum) consumption as close as possible. Figure 1

shows: At the moment up to 50 % of thermal energy in ceramic production is used for drying ⁴⁹. In the whole UK with its lot of stiff pressed bodies still 30% are used ⁹

- A common way to reduce the drying energy consumption in older companies is to couple the dryer and kiln. ⁷
- Today the coupling of dryer and kiln is state of the art, however it is also important to modify working practices i.e. weekend breaks for shaping and drying need to be carefully controlled. ⁴³
- Another method of modernising is to control the ventilation/burner system and the drying atmosphere. ⁶
- The use of small amounts of high temperature air, decreases air loss due to exhaust gases. ^{36, 45, 49}
- An impact flow (Fig. 8) of drying air is more efficient than a laminar flow and modernising of dryers is possible. ⁴
- Figure 2 shows that lowest energy costs (heat and electric) which can be reached at an optimum of heating energy and movement of drying air.
- The setters and the setting density should ensure that most of the surfaces are easily reached by the drying air. ⁵
- Shorter drying times save energy. ^{5, 6, 41, 44}
- To achieve the required humidity for drying avoid adding moisture and if required increase the setting density. ⁹
- Redirecting airflows can improve consistency and reduce drying time; intermittent airflow patterns can reduce drying time and improve yield. ⁹
- Software to simulate the drying process. Links to control data via specialized companies are a good way to optimise drying. ³⁶
- In the case of a coupled system between dryer and kiln, the kilns energy supply and not the dryers demand determines the energy level that the dryer gets, otherwise poor energy use in the dryer causes a higher energy consumption for firing. ^{36, 42}
- The system that connects the hot air from the kiln with the dryer should be well insulated. ⁴⁷

- Most modern drying equipment and technology can save up to 90% of drying time compared to conventional drying.⁴⁹
- Alternative drying systems are available using a steam atmosphere, this is called 'airless drying' and is claimed to have reduced drying times up to 80%.⁶³
- Alternative I/R burner systems are available using a mesh, these can be powered by a number of different gases are easy to control and are very energy efficient. These can be incorporated into existing dryer cabinets.⁶⁴

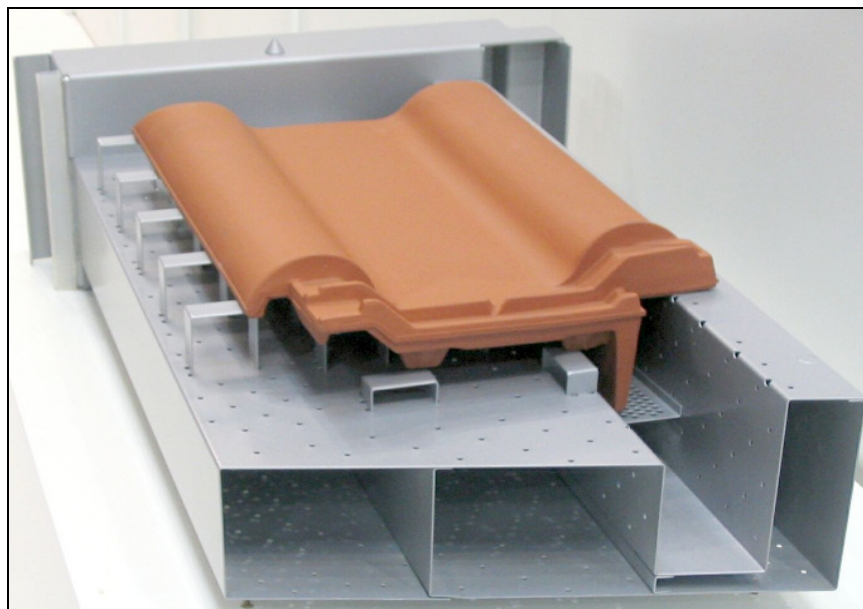

Figure 6: MobilSystem by Rotho- channel setter for roofing tiles⁴⁹



Figure 7: MobilSystem by Rotho- System of channel setters for roofing tiles⁴⁹

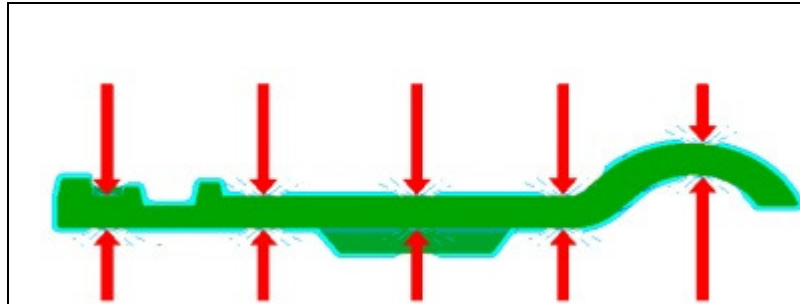

Figure 8: Impact flow, as optimal kind of drying for roof tiles

4.4 Firing

The specific energy consumption for sintering ceramic products depends on the required firing temperature. The temperature is determined by the composition of the body, the processes of material formation and the intended properties. Figure 3 shows an exponential increase of the specific demand for energy with the temperature.

Figure 4 shows the energy balance of a tunnel kiln for masonry bricks. These losses will be similar for roof tiles. The values of greatest loss are different exhaust air streams partly used for drying. Because of the higher firing temperatures and kiln furniture the SEC of a roof tile kiln is in average 2.5 times higher than the one used for masonry bricks. ⁴⁷

4.4.1 Kiln and kiln car design

There are two general ways of energy loss influenced by the design of the kiln and the kiln cars:

1. Leakages from surrounding air into the kiln

“However one of the best possibilities to save energy is still to eliminate leakages” Don Denison, Denison Inc. ²¹

2. Weight of kiln materials and kiln car materials that have to be heated

- “Wheel flanges of kiln car wheels should be in principle located on the outside”. ²
- “The kiln car decks should consist of high quality and lightweight insulating materials with a minimum content of heavy chamotte. It is recommended that the layers from the bottom deck to the top deck should be adapted to cope for the different respective temperature stresses”. ^{2, 3, 20}
- A picture for calculating the optimum car deck thickness can be seen in ².
- Sand seals should be designed to avoid leakages over a long time, suggestions are made in. ^{2, 33}
- Try to avoid self-supporting kiln sidewalls. Such walls tend to bend towards the firing channel because of the temperature differences over the cross section. It is important to consider the design very carefully and have a wall sustained by the kiln roof. ².
- Special designed kiln roofs avoid leakages due to heat expansion and make roof cooling redundant. ².
- The working load should be carried by special support units ² made from e.g. SiC.
- ¹⁴ describes a kind of roller kiln special designed for roof tiles, with extra light supports and firing time down to 120 min and very low SEC.

4.4.2 Fuel and firing technology

- In the main firing zone an excess pressure of 10-15 Pa is recommended.⁷⁴
- Use of renewable energies, i.e. bio-gases produced by companies in their own reactors can save costs and CO₂ emissions¹¹. However, bio-gases can't cover the whole energy need of a roof tile maker⁴⁷.
- Increasing control of firing with new burner systems and multi zone control.^{33,51,34}
- Impulse burners are more efficient than conventional ones.⁷⁴
- High velocity burners (velocity of heated gases > 100 m/s) are recommended for the preheating zone until 700 °C. At this lower temperature heating by convection mostly takes place. Kilns can be modernised with this modern kind of burners, to save energy.⁷⁴
- Techniques already described for drying are also important for firing.
- Allow the hot gases the best transfer to your working load.^{33,34}
- The combustion air should be preheated; at higher firing temperatures preheating saves energy. The preheating should be done by using kiln exhaust air.⁴⁰
- Use preheated working loads from the dryer, e.g. setting pallets for drying and firing or by direct setting on kiln cars for drying.^{1,23}
- The final development that some in the brick industry have used is emissivity coatings in certain sections of the kiln to reflect the heat to the required area thus reducing the temperature lag between 'part' and surrounding air. This in theory has reduced gas costs by up to 10%.⁵¹
- Reduce waste air losses by re-circulating them for heating over the whole length of kiln.³³
- Perfusion firing.⁴⁷
- Use heat recovery from waste gases and flue gas from post combustion.^{18,47}
- One tunnel kiln should work with one product and should be optimised for that product. With different products in the kiln no real optimisation can take place. Small intermittent kilns for special products or the cooperation with

different plants or reducing the number of different product types should be considered.⁹

- Kiln furniture is one of the greatest energy consumers with roof tile firing. Most modern types of H-setters have a bulk density of approx 1.6 g/cm and a weight saving design.^{15,24}
- The best setters for roof tiles are no setters e.g.^{22,39}
- Intermittent kilns for e.g. accessories can be operated much more energy efficient if heat recovery systems together with preheating of combustion air or coupled with dryers are used.

5 Tableware

5.1 Body and raw materials

The type of tableware body has essential influence on the SEC of the products. There is a broad range from stoneware, earthenware, bone china, vitreous china to hard porcelain plus many others. These have similar requirements and some differences concerning the properties. The greatest could be: resistance against dishwashers, important for both domestic and hotel purposes.³² Hard porcelain is the tableware with the greatest SEC (Fig. 3).

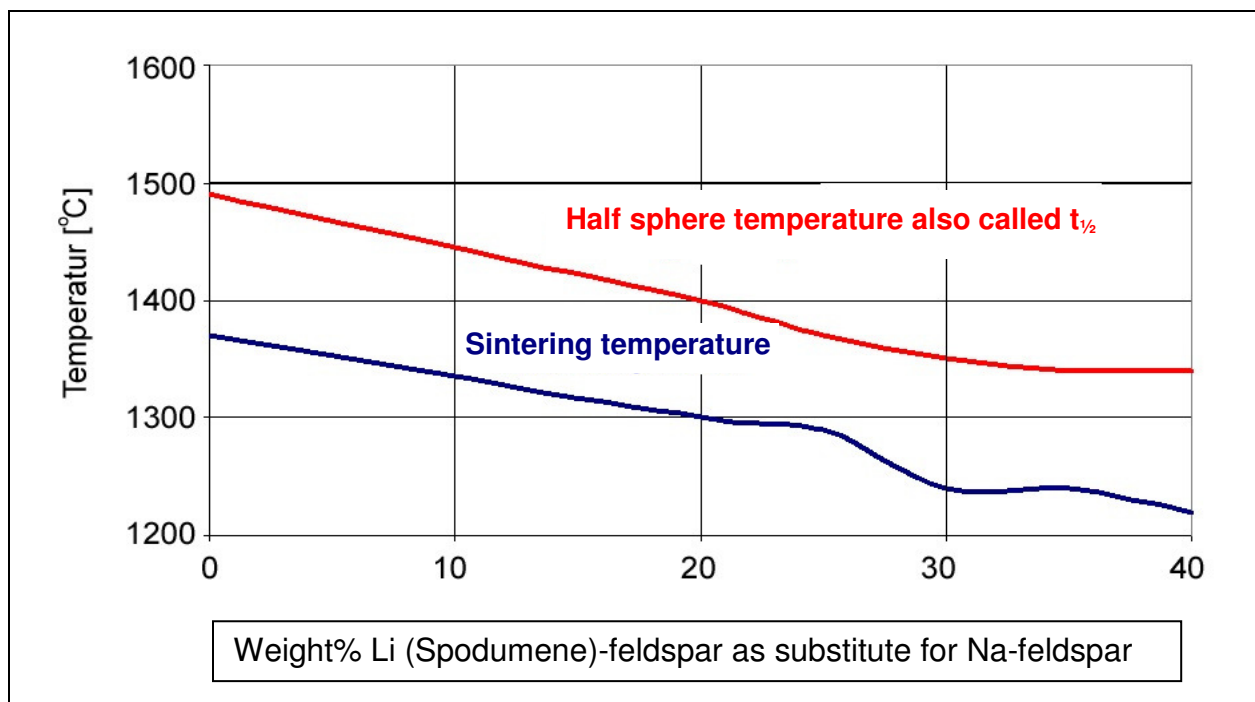

Figure 9: Effect of Li-Feldspar as sintering additive. Thierry SiliCer 2003

- New raw materials like Li-containing feldspars (Fig. 9)⁵³ or Colemanite²⁸, mixture of Feldspars from K and Na or low sintering recipes (soft porcelain) can help you to reduce sintering temperature for up to 200°C and to save lots of energy (Fig. 10).⁴⁸

- Mono firing (no bisque firing) saves energy, but requires specially tailored bodies and glazes.
- Shaping needs plasticity: It is necessary that the right amount of water is used to get the correct plasticity. Saving water by using better raw materials or adding special additives that help to get the correct plasticity is a way to save drying energy.³⁷

5.2 Shaping / Decorating

- The less water you need for shaping all the less you have to evaporate while drying.
 - Isostatic pressing is a 'dry pressing' technique hence water saving and eliminates the need for drying. If this technique is available use it for as many products as possible; today also bowls are possible to shape by this.
 - Most modern isostatic pressing methods need less than 2 weight% of moisture.
 - No drying of plaster moulds has to take place if isostatic pressing methods are used.
 - Isostatic pressing needs spray dried granules, the less water you use for your deflocculating, the less energy you have to use for that process (see also paragraph about drying in "Tiles"-section).
 - Use high litre weights for your casting slips; this will require less energy for drying the plaster moulds.
- Sophisticated design can avoid parts of tableware pieces that require longer drying or firing.
- The more colours your decoration allows within one firing step the less energy you need for decorating firing.
- Develop a smart storage of products and decors that allows you to dry and fire greater batches of products, that saves energy.

- Smarter process control for shapes and decors allows you to optimise your production process allowing for reduced energy consumption.
- Using novel shaping techniques (flexi flat) that use fewer moulds that don't require drying saves energy.⁶⁶
- The use of more energy efficient burners, which can be switched off when not required should be employed in the glazing line.⁶⁴

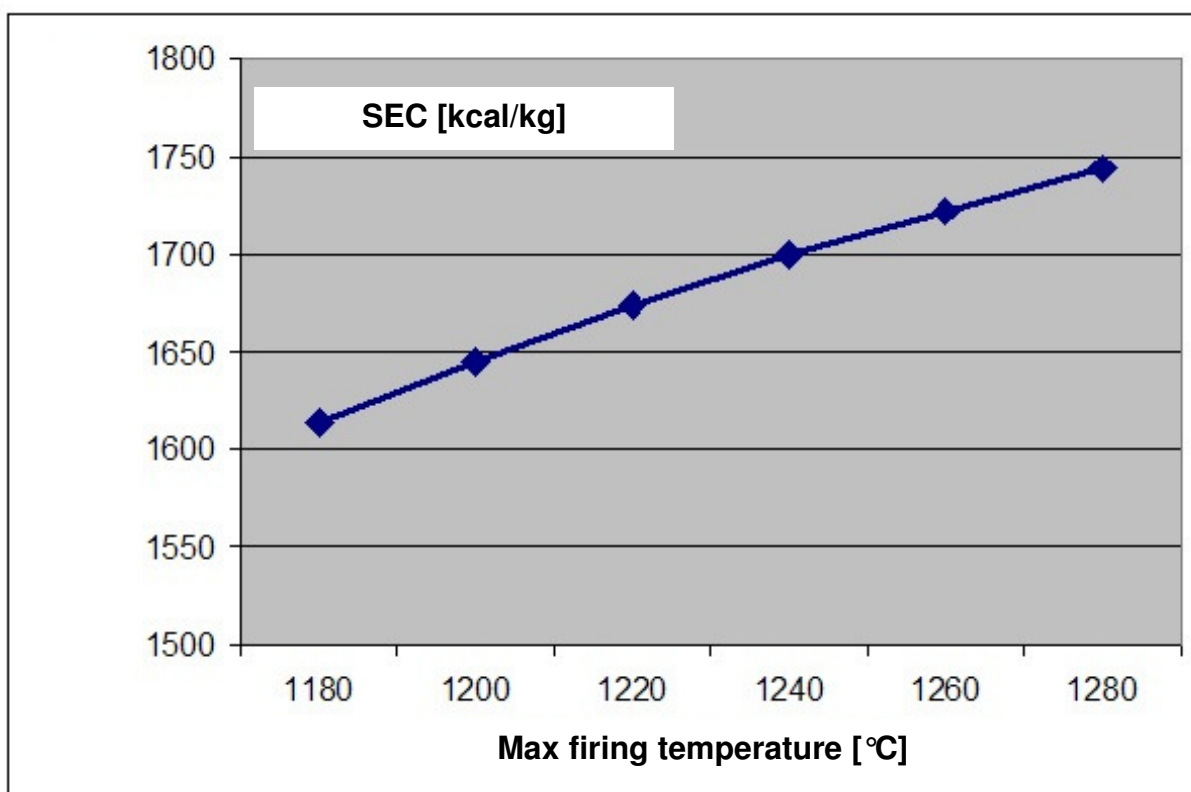

Figure 10: SEC vs. firing temperature for sanitary ware. [Friedherz Becker, Riedhammer GmbH 2007]

5.3 Drying

In the ceramic industry drying generally means the evaporation or volatilisation of physically bound water. It is well known that water is characterised by a high specific thermal capacity (4.2 kJ/kg K) and a very high evaporation heat (2.500 kJ/kg). These material properties inevitably cause a high-energy consumption.

- In Europe a lot of tableware production plants have enough space and a sufficient climate allowing them to dry without a dryer i.e. in the surround air; however this is not always the case in the UK, with the exception of isostatic pressed products. This is the most energy efficient drying process.
- For products from casting processes an increasing number of microwave dryers are used to save energy.
- Poor drying conditions are sometimes visible first after firing. This increases your scrap and your SEC,⁵⁸ good quality control measures should be used to identify the problems.
- The use of airless drying can reduce your energy consumption by up to 80% and also improve your quality.⁶⁸

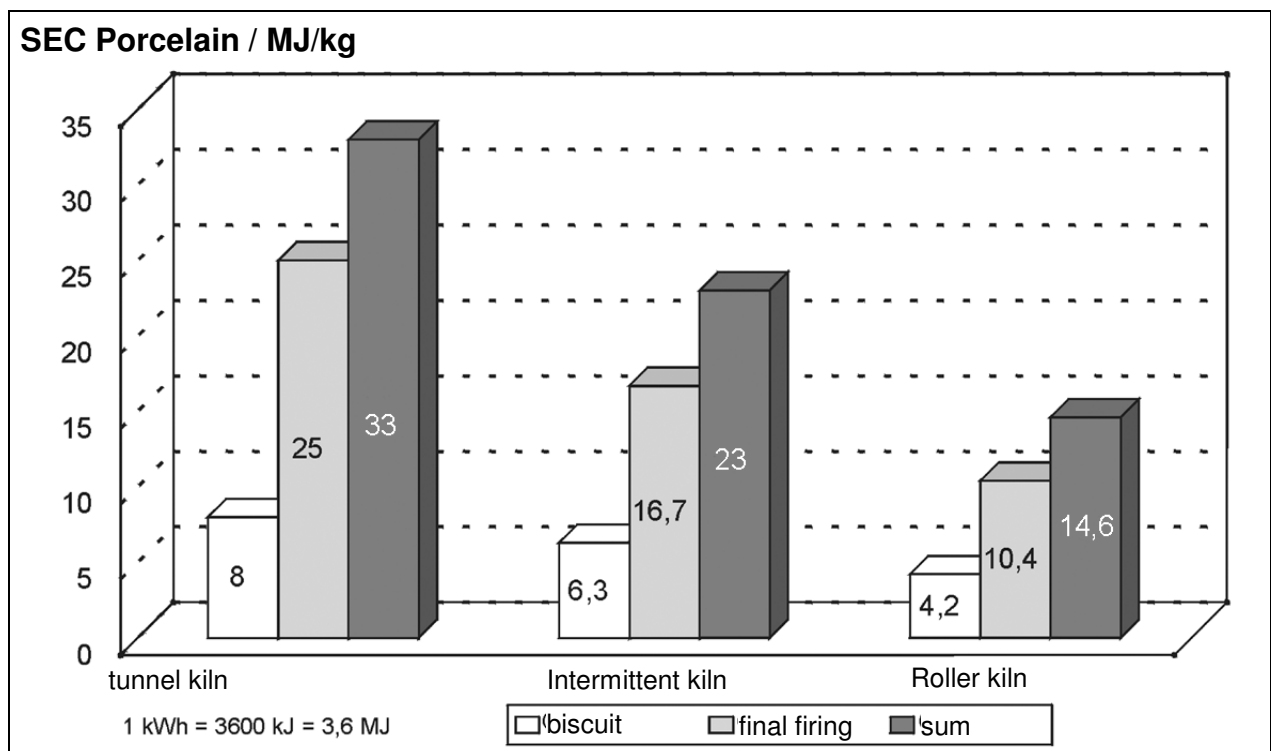

Figure 11: Comparison of different kilns for different steps of firing in table ware production

5.4 Firing

The specific energy consumption for sintering ceramic products depends on the required firing temperature. The temperature is determined by the composition of the body, the processes of material formation and the intended properties. Figure 3 shows an exponential increase of the specific demand for energy with the temperature.

5.4.1 Kiln and kiln car design

Figure 11 shows the SEC of 3 different kiln types used for Hard Porcelain tableware firing. It is obvious that the roller kiln with its small amount of kiln furniture and its fast firing process uses the smallest amount of energy, just half of a tunnel kiln.

There are two general ways of energy loss influenced by the design of the kiln and the kiln cars:

1. Leakages from surrounding air into the kiln

”However one of the best possibilities to save energy is still to eliminate leakages” Don Denison, Denison Inc.²¹

2. Weight of kiln materials and kiln car materials that have to be heated

- “Wheel flanges of kiln car wheels should be in principle located on the outside”.²
- “The kiln car decks should consist of high quality and lightweight insulating materials with a minimum content of heavy chamotte. It is recommended that the layers from the bottom deck to the top deck should be adapted to cope for the different respective temperature stresses”.^{2, 3, 20}
- Sand seals should be designed to avoid leakages over a long time, suggestions are made in.^{2, 33}

- Try to avoid self-supporting kiln sidewalls. Such walls tend to bend towards the firing channel because of the temperature differences over the cross section. It is important to consider the design very carefully and have a wall sustained by the kiln roof.²
- Special designed kiln roofs avoid leakages due to heat expansion and make roof cooling redundant.²

5.4.2 Fuel and firing technology

- There is an example of updating an old tunnel kiln to an modern fast firing one, that dropped the gas consumption almost 50 % .⁵⁰
- In the main firing zone an express pressure of 10-15 Pa is recommended.⁷⁴
- For mono firing the biscuit firing is cancelled however special glazes and bodies are required. Figure 11 shows the amount of energy that is saved.
- Increasing control of firing with new burner systems and multi zone control.^{33,51,34}
- Impulse burners are more efficient than conventional ones.⁷⁴
- High velocity burners (velocity of heated gases > 100 m/s) are recommended for the preheating zone until 700 °C. At this lower temperature heating by convection mostly takes place. Kilns can be modernised with these modern kinds of burners, to save energy.⁷⁴
- Techniques already described for drying are also important for firing.
- Allow the hot gases the best transfer to your working load.^{33,34}
- The combustion air should be preheated; at higher firing temperatures preheating saves energy. The preheating should be done by using kiln exhaust air.⁴⁰
- Reduce waste air losses by reusing it to heat on the whole length of kiln.³³
- Organise your production to produce one product over a longer range of time. Try to optimise your temperature curve for that product. With different products in the kiln it is more difficult for real optimisation to take place. Think

about small intermittent kilns. For small batches think about cooperation with different plants or about reducing the number of different product types.⁹

- Heat recovery from waste gases.⁴⁷
- Kiln furniture is one of the greatest energy consumers. Most modern types of kiln furniture are made from SiC and have a weight saving design.⁴⁸
- The best setters for tableware are “No” setters in e.g. roller kilns.
- The lower your amount of scrap, the lower is your SEC.⁷⁴
- Intermittent kilns can be operated much more energy efficiently if heat recovery systems together with preheating of combustion air or are coupled with dryers.^{8,27}

6 Sanitary ware

6.1 Body and raw materials

- New raw materials like Li-containing feldspars (Fig. 9⁵³) or Colemanite²⁸ and mixtures of Feldspars from K and Na; waste glasses^{60, 69} help you to reduce sintering temperature for up to 200 °C and to make energy savings (Fig. 10).⁴⁸
- Optimised bodies from traditional clays and china clays can decrease firing temperature up to 50 °C.⁵⁵
- Optimise grain size distribution especially for feldspar and other sintering additives decreases sintering temperature by improving the reactivity.⁶²
- There is an optimum, because milling of e.g. feldspars requires energy as well.
- Optimise bodies for fast firing kilns with e.g. calcined raw materials.
- Shaping needs plasticity. It is necessary that the right amount of water is used to get the correct plasticity. Saving water by using better clays that are easy to form or adding special additives that help to get the correct plasticity is a way to save drying energy.³⁷

6.2 Shaping / Decorating

- The less water you need for shaping the less you have to evaporate while drying.
- Pressure casting techniques avoid drying of plaster moulds and decrease water content by up to 2 weight%, but need tempered slips and electric energy.
- Use high litre weights for your casting slips, as your plaster moulds will dry with less energy.

- Sophisticated design can avoid that parts of your products needs longer drying or firing.
- Better production planning of products allows you to dry and fire greater batches of products, which saves energy.
- Small numbers of different products allows you to optimise your production process also for energy consumption.
- Logos and Badging is being carried out by laser marking/fusing of ceramic pigments and is a non firing process. This has a number of advantages i.e. reduction of stock and losses of badge creep during refire.

6.3 Drying

In the ceramic industry drying generally means the evaporation or volatilisation of physically bound water. It is well known that water is characterised by a high specific thermal capacity (4.2 kJ/kg K) and a very high evaporation heat (2.500 kJ/kg). These material properties inevitably cause a high-energy consumption.

- A common way to reduce the drying energy consumption in older companies is to couple the dryer and kiln.⁷
- Today the coupling of dryer and kiln is state of the art, however it is also important to modify working practices i.e. weekend breaks for shaping and drying need to be carefully controlled.⁴³
- Another method of modernising is to control the ventilation/burner system and the drying atmosphere.⁶
- The use of small amounts of high temperature air, decreases air loss due to exhaust gases.^{36, 45, 49}
- Figure 2 shows that lowest energy costs (heat and electric) which can be reached at an optimum of heating energy and movement of drying air.
- For products from casting processes an increasing number of microwave dryers are used to save energy.



- Poor drying conditions are sometimes visible first after firing, this increases your scrap and your SEC,⁵⁸ good quality control measures should be used to identify the problems.
- The use of airless drying can reduce your energy consumption by up to 80% and also improve your quality.⁶³
- Shorter drying times save energy.^{5, 6, 41, 44}
- To achieve the required humidity for drying avoid adding moisture and if required increase the setting density.⁹
- Redirecting airflows can improve consistency and reduce drying time; intermittent airflow patterns can reduce drying time and improve yield.⁹
- Software to simulate the drying process. Links to control data via specialized companies are a good way to optimise drying.³⁶
- In the case of a coupled system between dryer and kiln, the kilns energy supply and not the dryers demand determines the energy level that the dryer gets, otherwise poor energy use in the dryer causes a higher energy consumption for firing.^{36, 42}
- The system that connects the hot air from the kiln with the dryer should be well insulated.⁴⁷

6.4 Firing

The specific energy consumption for sintering ceramic products depends on the required firing temperature. The temperature is determined by the composition of the body, the processes of material formation and the intended properties. Figure 3 shows an exponential increase of the specific demand for energy with the temperature.

	Temperature [°C]	SEC [MJ/kg]	Capacity [t/h]
Old tunnel kiln	1200-1280	6,7-9,2	10-50
Modern tunnel kiln (fibre and light refractories)	1230-1260	4,2-6,7	10-50
Roller kiln	1230-1260	3,1-4,2	10-30

Table 3: SEC for different kiln types in the sanitary ware branch according to ⁵⁴

6.4.1 Kiln and kiln car design

Table 3 shows the SEC of 3 different kiln types used for sanitary ware firing. It is obvious that the roller kiln with its small amount of kiln furniture and its fast firing uses the smallest amount of energy, namely just a third of a tunnel kiln.

There are two general ways of energy loss influenced by the design of the kiln and the kiln cars:

1. Leakages from surrounding air into the kiln

”However one of the best possibilities to save energy is still to eliminate leakages” Don Denison, Denison Inc.²¹

2. Weight of kiln materials and kiln car materials that have to be heated

- “Wheel flanges of kiln car wheels should be in principle located on the outside”.²
- “The kiln car decks should consist of high quality and lightweight insulating materials with a minimum content of heavy chamotte. It is recommended that the layers from the bottom deck to the top deck should be adapted to cope for the different respective temperature stresses”.^{2, 3, 20}
- Sand seals should be designed to avoid leakages over a long time, suggestions are made in.^{2, 33}
- Try to avoid self-supporting kiln sidewalls. Such walls tend to bend towards the firing channel because of the temperature differences over the cross section. It is important to consider the design very carefully and have a wall sustained by the kiln roof.²
- Special designed kiln roofs avoid leakages due to heat expansion and make roof cooling redundant.

6.4.2 Fuel and firing technology

- In the main firing zone an excess pressure of 10-15 Pa is recommended.⁷⁴
- The lower your amount of scrap, the lower is your SEC. Re-firing increases your SEC.⁷⁴
- Increasing control of firing with new burner systems and multi zone control.^{33,51,34}
- Impulse burners are more efficient than conventional ones.⁷⁴
- High velocity burners (velocity of heated gases > 100 m/s) are recommended for the preheating zone until 700 °C. At this lower temperature heating by convection mostly takes place. Kilns can be modernised with this modern kind of burners, to save energy.⁷⁴
- Techniques already described for drying are also important for firing.
- Allow the hot gases the best transfer to your working load.^{33,34}
- The combustion air should be preheated; at higher firing temperatures preheating saves energy. The preheating should be done by using kiln exhaust air.⁴⁰
- Organise your production to produce one product over a longer range of time. Try to optimise your temperature curve for that product. With different products in the kiln it is more difficult for real optimisation to take place. Think about small intermittent kilns. For small batches think about cooperation with different plants or about reducing the number of different product types.⁹
- Heat recovery from waste gases.⁴⁷
- Kiln furniture is one of the greatest energy consumers. Most modern types of kiln furniture are made from SiC and have a weight saving design.⁴⁸
- The best setters for sanitary ware are “No” setters in e.g. roller kilns.
- The lower your amount of scrap, the lower is your SEC.
- Intermittent kilns can be operated much more energy efficiently if heat recovery systems together with preheating of combustion air or are coupled with dryers.^{8,27}

7 Tiles

7.1 Body and raw materials

- New raw materials like Li-containing feldspars (Fig. 9⁵³) or Colemanite²⁸, mixtures of Feldspars from K and Na or low sintering recipes can help you to reduce sintering temperature for up to 200 °C and to save lots of energy (Fig. 10).⁴⁸
- Optimised bodies from traditional clays and china clays can decrease firing temperature up to 50 °C.⁵⁵
- Optimise bodies for fast firing kilns with e.g. calcined raw materials.
- Spray drying needs the optimal litre weight: Saving water by using better raw materials or special additives which decrease water content of slip is a way to save drying energy.
- Continuous mills save up to 2 % of water of slip and increases slip temperature up to 10 °C (and decreases electric power consumption)⁷²

7.2 Spray drying / Drying

In the ceramic industry drying generally means the evaporation or volatilisation of physically bound water. It is well known that water is characterised by a high specific thermal capacity (4.2 kJ/kg K) and a very high evaporation heat (2.500 kJ/kg). These material properties inevitably cause a high-energy consumption, especially for spray drying of slips where water contents up to 50 weight% are common.

- One of the most energy efficient kinds of spray drying is the cogeneration of heat and power. Figure 12 shows the excellent degree of effectiveness (approx. 90%) for that solution⁷³.
- The higher the litre weight, the lower the energy consumption of the spray dryer (fixed remaining moisture for pressing).⁵⁹

- The energy consumption of spray drying decreases for smaller granules, if the quality demands allow.
- The better the insulation of each spray dryer, the lower is the energy consumption.
- Preheat the combustion air for burners with waste heat from the kiln or spray dryer (Figure 13)⁷³.
- Instead of cyclones a dust separator and slip heater can be used. The remaining dust from the spray dryer is washed out by the slip. The slip is heated from this process. Recommended for slips that are milled by discontinuous mills (Figure 14)⁷³.

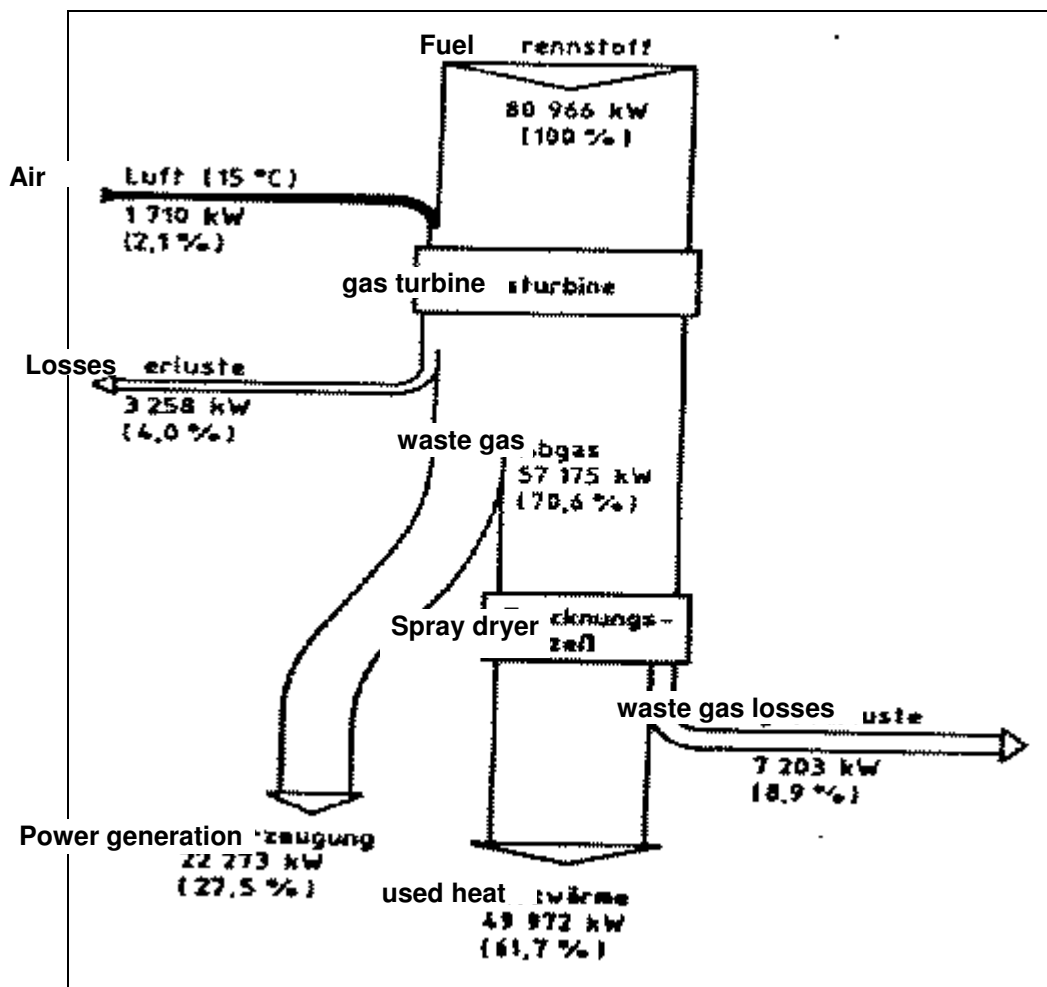

Figure 12: Balance of cogeneration of heat and power, if a spray dryer is used ⁵⁶

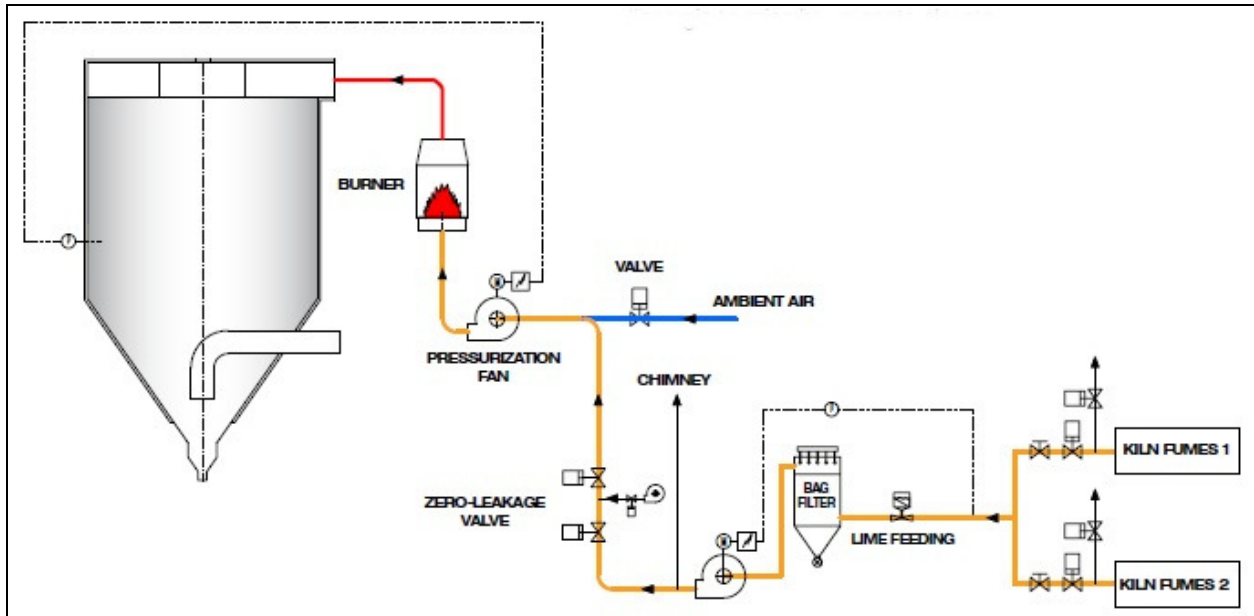

Figure 13: Recovery of cooling or fuming heat from kiln for spray drying (by SACMI)⁷³

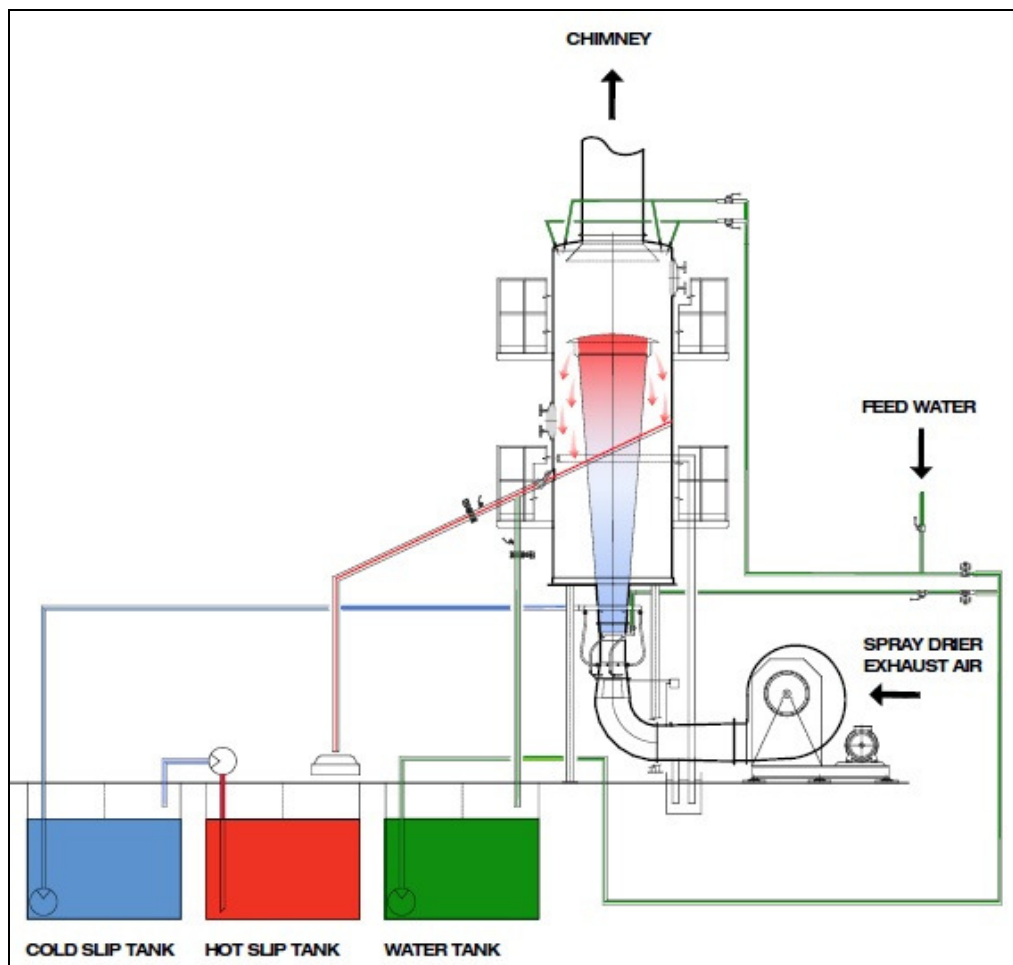

Figure 14: Dust separator for waste air from spray dryer and slip heating (by SACMI)⁷³

- Vertical or horizontal post press dryers should be feed by hot cooling air from the kiln. Examples are shown in ⁷⁰.

7.3 Shaping / Decorating

- Better production planning of products allows you to dry and fire greater batches of products, which saves energy.
- Small numbers of different products allows you to optimise your production process also for energy consumption.

7.4 Firing

The specific energy consumption for sintering ceramic products depends on the required firing temperature. The temperature is determined by the composition of the body, the processes of material formation and the intended properties. Figure 3 shows an exponential increase of the specific demand for energy with the temperature.

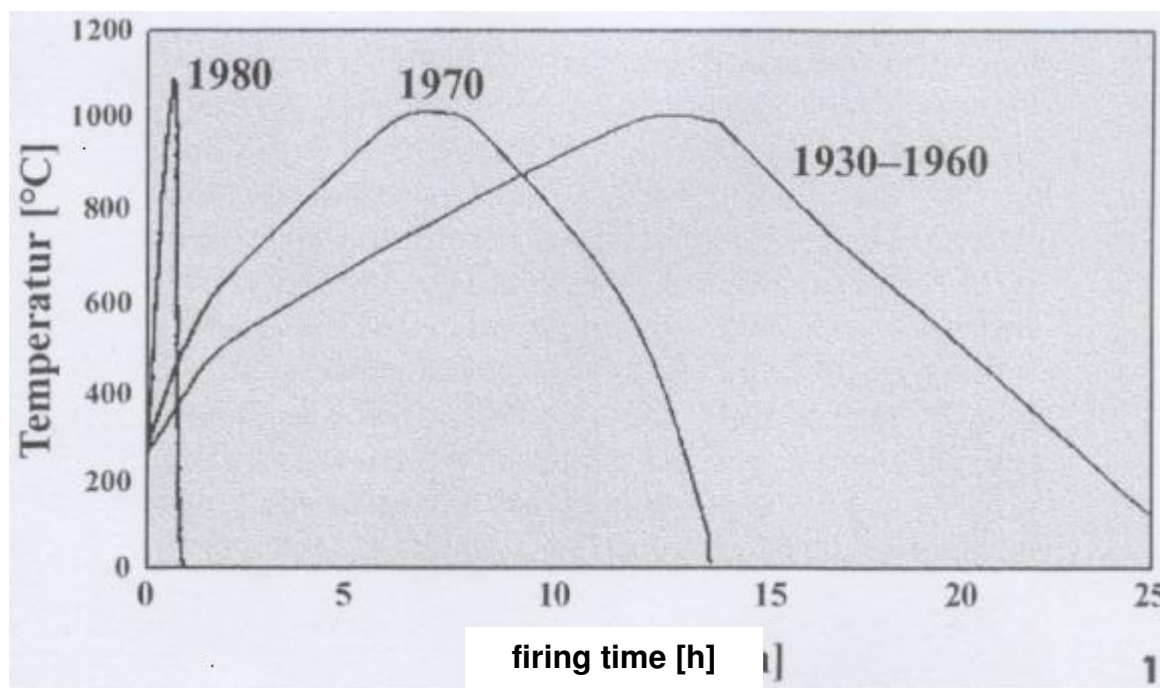

Figure 15: Decreasing firing time for tiles during the 20th century ⁵⁵

7.4.1 Kiln and kiln car design

Table 3 and Figure 11 show the SEC of 3 different kiln types used for sanitaryware and tableware firing respectively. It is obvious that the roller kiln with its small amount of kiln furniture and its fast firing uses the smallest amount of energy, namely just a third of a tunnel kiln. Figure 15 shows the shortening of firing time for tiles during the last century. The roller kiln was responsible for this development. Due to its low energy consumption and the easy shape of tiles this type of kiln is state of the art for the firing of tiles.

There are two general ways of energy loss influenced by the design of the kiln and the kiln cars:

1. Leakages from surrounding air into the kiln

”However one of the best possibilities to save energy is still to eliminate leakages” Don Denison, Denison Inc.²¹

2. Weight of kiln materials and kiln car materials that have to be heated

- The rollers should be sealed well
- “The kiln car decks should consist of high quality and lightweight insulating materials with a minimum content of heavy chamotte. It is recommended that the layers from the bottom deck to the top deck should be adapted to cope for the different respective temperature stresses”.^{2, 3, 20}
- Special designed kiln roofs avoid leakages due to heat expansion and make roof cooling redundant.²

7.4.2 Fuel and firing technology

- In the main firing zone an express pressure of 10-15 Pa is recommended.⁷⁴
- The lower your amount of scrap, the lower is your SEC.⁷⁴



- Increasing control of firing with new burner systems and multi zone control.^{33,51,34}
- Impulse burners are more efficient than conventional ones.⁷⁴
- High velocity burners (velocity of heated gases > 100 m/s) are recommended for the preheating zone until 700 °C. At this lower temperature heating by convection mostly takes place. Kilns can be modernised with this modern kind of burners, to save energy.⁷⁴
- The combustion air should be preheated; at higher firing temperatures preheating saves energy. The preheating should be done by using kiln exhaust air.^{40, 71}
- Organise your production to produce one product over a longer range of time. Try to optimise your temperature curve for that product. With different products in the kiln it is more difficult for real optimisation to take place. Think about small intermittent kilns. For small batches think about cooperation with different plants or about reducing the number of different product types.⁹
- Heat recovery from waste gases.⁴⁷

8 References

1. Gres Acueducto, S.A.: The works and the products an unqualified success. ZI Ziegelindustrie International, 2000, 5, 23-30
2. Riedel, R.: The real snag lies in the detail part 1 und 2. ZI Ziegelindustrie International, 2000, 6 und 9, 29-37, 23-32
3. Hesse, V.: The problems of energy consumption of tunnel kiln cars in fast firing tunnel kilns. ZI Ziegelindustrie International, 2001, 3, 13-20
4. Schlosser, M.: New concepts for tile setters and rapid drying in the clay roofing tile industry. ZI Ziegelindustrie International, 2001, 1/2, 25-29
5. Ceramicas Casao: High quality, large capacity and low energy consumption. ZI Ziegelindustrie International, 2001, 7, 24-28
6. Bauhütte Leitl-Werke GmbH: "Eco Brickworks 2000" operating at full capacity. ZI Ziegelindustrie International, 2001, 5, 16-24
7. Vissing, L.: Energy consumption in the Danish brick industry. ZI Ziegelindustrie International, 2003, 3, 21-27
8. Strohmenger, P.: Energy saving intermittent kiln with heat exchanger system. ZI Ziegelindustrie International, 2003, 3, 36-39
9. www.tangram.co.uk: Energy efficiency in ceramics processing.
<http://www.tangram.co.uk/>
10. Jüchter, M.: Modernization of an existing plant an economical alternative. ZI Ziegelindustrie International, 2004, 3, 20-23
11. Mödinger, F.: The utilization of biogas at brickworks. ZI Ziegelindustrie International, 2004, 5, 20-31
12. Bayrische Dachziegelwerke Bogen GmbH: Innovative tunnel kiln for accessories at Bogen roofing tile works. ZI Ziegelindustrie International, 2004, 9, 36-39
13. Brick and Tile of Lawrenceville: A new manufacturing plant for for brick an tile Corporation of Lawrenceville. ZI Ziegelindustrie International, 2004, 10, 22-26
14. Ronchetti, R.: A new type of kiln for rapid firing of clay roof tiles. ZI Ziegelindustrie International, 2004, 11, 38-42

15. *Hohlfeld, K.*: Reduced kiln furniture weight for H-setters for firing roof tiles. ZI Ziegelindustrie International, 2005, 3, 19-28
16. *Mödinger, F.*: Options for the use renewable fuels in tunnel kilns. ZI Ziegelindustrie International, 2006, 8, 44-53
17. *Aubertot, C.*: Petroleum coke - a fuel of the future. ZI Ziegelindustrie International, 2006, 9, 36-40
18. *Rieger, W.*: Flue gas post-combustion in tunnel kilns with utilization of the released heat of combustion for brick drying and firing. ZI Ziegelindustrie International, 2007, 9, 32-42
19. *Dörr, J.*: Pore-forming with carboniferous clay blends - without strength loss but with a simultaneous energy saving. ZI Ziegelindustrie International, 2006, 5, 122-129
20. *Kettler, H.*: Kiln car engineering and energy conservation. ZI Ziegelindustrie International, 2006, 5, 130-133
21. anonymous: "International Brick Plant Operator's Forum" in Clemson (USA) with focus on energy saving. ZI Ziegelindustrie International, 2006, 12, 8-13
22. *Mori, G.*: Röben clay roofing tile plant in Sroda Slaska - designed for 40 million tiles and 4 million accessories per year . ZI Ziegelindustrie International, 2006, 9, 18-27
23. *Rieger, W.*: New design of a tunnel kiln structure made of prefabricated lightweight chamotte elements and replacement of the kiln cars by firing pallet circuit. ZI Ziegelindustrie International, 2007, 6/7, 45-55
24. *Kettler, H.*: BurcoLight - Results from practical operations. ZI Ziegelindustrie International, 2008, 5, 21-28
25. *Industrie Pica S.p.A.*: A new innovative clay roofing tile works at Portacomara. ZI Ziegelindustrie International, 2008, 8, 46-52
26. *Unieco Fornace di Fosdondo*: Newly developed dryer for the brick factory Fornace di Fosdondo. ZI Ziegelindustrie International, 2008, 1/2, 51-54
27. *Strohmenger, P.*: Energy saving Bogie-hearth furnace with heat Exchanger-System, Keramische Zeitschrift, 2003, 5, 350-352
28. *Kartal, A.*: Untersuchungen zur Erstellung von Hartporzellan bei verringerten Brenntemperaturen. cfi/Ber. DKG, 2004, 5, D20-D22

29. Rambaldi, E.: Glass recycling in porcelain stoneware tiles: Firing behaviour. cfi/Ber. DKG, 2004, 3, E32 - E 36
30. Coudamy, G.: Energy Saving and optimised firing thanks to new technology: "Entropy+". cfi/Ber. DKG, 2003, 9, E53-E60
31. Hansen, H.: Intelligente HAT-Herdwagenöfen. cfi/Ber. DKG, 2006, 11/12, D15-D16
32. Müller-Zell, A.: Niedrig sinternde Fertigmassen für Geschirr. cfi/Ber. DKG , 2008, 11, D15-D16
33. Fischer, M.: Möglichkeiten und Grenzen der Energieeinsparung. cfi/Ber. DKG , 2009, 2, D14-D18
34. Slater, A.: Fire more or less. cfi/Ber. DKG , 2009, 2, E35-E39
35. Junge, K.: Sintering aids for reducing the final firing temperature and energy saving. ZI Ziegelindustrie International, 1998, 10, 686-687
36. Leisenberg, W.: Ways to efficient use of energy. ZI Ziegelindustrie International, 1998, 7, 434-440
37. Bohlmann, C.: Reduction of mixing water with additives - a contribution to energy cost saving. ZI Ziegelindustrie International, 1998, 1/2, 35-43
38. König, R.: The "Laminaris" at the Staudacher Brickworks - a further advance in drying technology. ZI Ziegelindustrie International, 1999, 9, 67-71
39. Masatishi Nakashima, J.: Clay roofing tile production in Japan. ZI Ziegelindustrie International, 1999, 3, 11-17
40. Riedel, R.: Combustion air preheating. ZI Ziegelindustrie International, 1999, 11, 30-39
41. Rapis-Ziegel Schmidt GmbH: New drying technology in the Rapis brickworks. ZI Ziegelindustrie International, 1999, 9, 73-78
42. Vogt, S.: Way to efficient use of energy. ZI Ziegelindustrie International, 1998, 8, 496-501
43. Junge, K.: Effects of the ban on Sunday working on the energy consumption of heavy clay works. ZI Ziegelindustrie International, 1998, 6, 327-335
44. König, R.: The Laminaris rapid dryer at the Tonwerk Venus in Schwarzach. ZI Ziegelindustrie International, 1998, 8, 502-508

45. Denissen, J.A.M.: Energy efficient drying, Part 1: Energy efficiency of various techniques in convective drying. ZI Ziegelindustrie International, 1998, 8, 509-517
46. Häbller, A.: A new continuous system for drying, firing and transport. ZI Ziegelindustrie International, 1998, 8, 519-521
47. Hobohm, F.: Maßnahmen zur Energieeinsparung. www.keramikinstitut.de, 2008
48. Bartusch, R.: Potential for saving energy in the Ceramic Industry. Keramische Zeitschrift, 2002, 1, 6-10
49. Vogt, S.: Fortschrittliche Trocknungstechnik. www.keramikinstitut.de, 2008
50. Jaegermann, Z.: Information Polish table ware branch, personally, 2009, 3.
51. Cartlidge D.: New techniques in the brick industry of the UK, personally, 2009, 3.
52. Petersminde Teglvaerk A/S, Stenstrup, Fünen, DK: A modern tunnel kiln for the manufacture of a wide assortment of facing bricks. ZI Ziegelindustrie International, 2005, 7, 14-17
53. Telle, R: Senkung der Brenntemperaturen bei Sanitärporzellan durch Lithium-Zugaben, www.keramikinstitut.de, 2007
54. Sladek, R.: Gegenwärtiger Stand der Technik im Brennverfahren für sanitärkeramische Produkte, Keramische Zeitschrift 47 (1995) 5
55. Schulle, W.: Entwicklungen und Probleme beim Schnellbrand keramischer Produkte. Keramische Zeitschrift 52 (2000) 12
56. Köhler, R.: Personal talks with German tile producers
57. Vouillemet, M.: Le séchage mixte air chaud / micro-ondes des moules en plâtre neufs pour l'industrie du sanitaire. L'Industrie Céramique & Verrière 899 , 12/94, 780-784
58. Vouillemet, M: Le séchage en céramique. Les Techniques de l'Industrie Minérale 8, 12/2000, 93-98.
59. Blanc J.J.: The real costs of the dispersion of spray dried bodies. Ceramic World Review 70, 01-01/2007, 148-155
60. Blanc J.J.: Valorisation des déchets de verre dans les céramiques vitrifiées. L'Industrie Céramique & Verrière 953, 01/2000, 671-676
61. Vouillemet, M.: L' apport des micro-ondes comme source d'énergie en céramique. Réduction des cycles de traitement thermique et optimisation de la

qualité des produits. Séchage mixte micro-ondes / air chaud des sanitaires : résultats pilotes et applications possibles.

62. Blanc J.J.: La granularité des poudres en céramique. Finesse et réactivité des feldspaths pour vitreous sanitaire. Mines & Carrières 81, 07-08/99, 28-31.

63. J. Fifer: Commercial case for airless drying. Br Ceram Trans 97, No 2, 1998, p80 - 82

64. *Cartlidge D*: Personal: Infrared burner system that can be controlled in red and blue mode with the heating surface being a Sintered Nit. 2009

65. WRAP: Glass in Bricks and Tiles. (UK website)

66. *Cartlidge D*: Personal: flexi flat roller making. 2009

67. *Cartlidge D*: Personal: laser decoration for sanitaryware. 2009

68. Airless drying shapes up to Tableware challenge. Global Ceramic Review, No 2/99, summer 1999

69. *Cartlidge D*: Use of waste glasses in sanitaryware production. 2009

70. SACMI Imola S. C:

http://www.sacmi.com/System/00/01/25/12544/633600971649531250_1.pdf

71. SACMI Imola S. C:

http://www.sacmi.com/System/00/01/25/12542/633600970754531250_1.pdf

72. SACMI Imola S. C:

http://www.sacmi.com/System/00/01/25/12552/633601079876875000_1.pdf

73. SACMI Imola S. C:

http://www.sacmi.com/System/00/01/25/12553/633601080867187500_1.pdf

74. *Petzold, J*: Personal recommendations about operating ceramic kilns